

# Rigid Insulation for Plastics and Rubber Processing

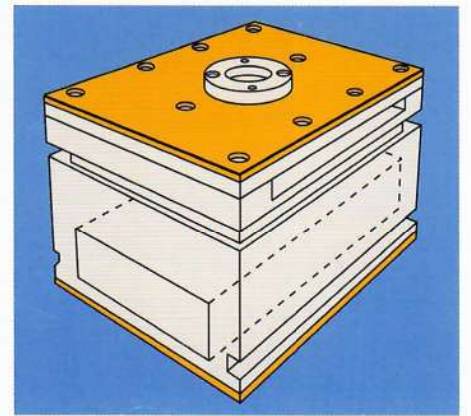
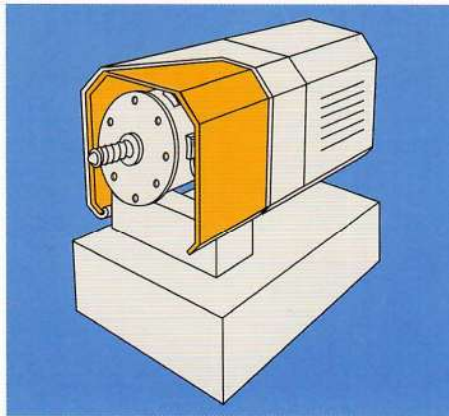
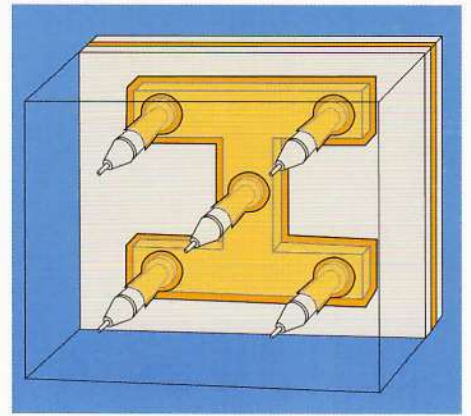
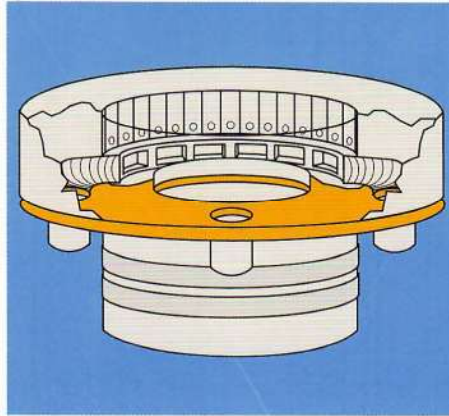

**PYROPEL®**

# The First Insulation Designed Specifically

## Superior Insulating Properties and Unmatched Ease of Use

Pyropel® is the first insulation developed specifically to meet the stringent demands of plastics and rubber processors. Pyropel is a unique, rigid, lightweight polyimide fiberboard with superior insulating properties across a broad temperature range. Produced through a patented process in which it is three-dimensionally reinforced, it is self-supporting and exceptionally tough and durable.

Pyropel offers an unmatched combination of insulating performance, design freedom, and assembly advantages.

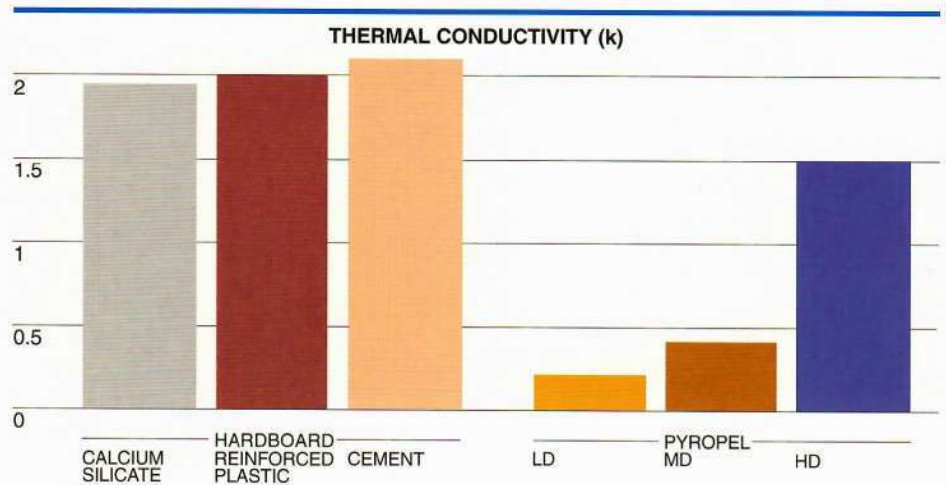

## 2 to 4 Times More Effective Than Other Common Insulation

Thermal conductivity is the measure of the amount of heat transferred by or through a material. When comparing insulation, the lower its thermal conductivity, the better a material's insulating capability.

As the graph above shows, Pyropel is 2 to 4 times more effective than other insulation materials typically used in plastics and rubber processing. This superior insulating capability is due to a patented manufacturing process that creates sintered fiber bundles. These bundles give Pyropel its rigidity, compressive strength, and durability. They also trap and hold air, making Pyropel a highly effective insulator.

## Will Not Crack Under Pressure

Many organic insulation boards crack when subjected to compression forces, thermal expansion, or thermal shock.



Because of its unique thermoset fiber construction, Pyropel is compression-resistant, yet nonbrittle. It will not crack—even in extreme conditions. Consequently, Pyropel offers significantly longer service life and dramatically reduces the time spent replacing worn or broken insulation.

## Easy to Cut, Machine, and Fabricate

Common insulation boards are hard to work with. In many cases, they require special tools and machining skills—tools and skills which many plastics processors do not have in-house. As a result, many plastics processors pay outside specialists to fabricate their insulation boards.

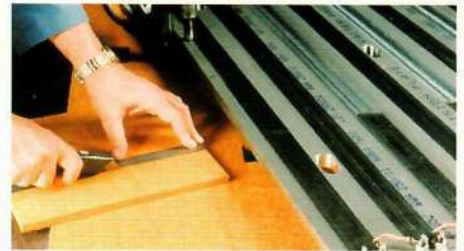

Pyropel is easy to use and requires no special tools. It handles like wood or any free-machining plastic. Pyropel can be drilled, milled, routed, and sawed using standard wood or metalworking tools.





# for Plastics and Rubber Processing



Pyropel can also be easily fabricated into custom insulation packages for areas that previously could not be insulated.

## Easy To Install Using Mechanical Fasteners or Adhesives

Pyropel can be easily installed on process equipment or tooling using simple fasteners or adhesives. Rigid and self-supporting, it eliminates the need for special support structures and associated design considerations.



## Available in a Range of Thicknesses and Densities

Manufactured in a wide variety of product types, Pyropel is available in a thickness and density to meet your specific application

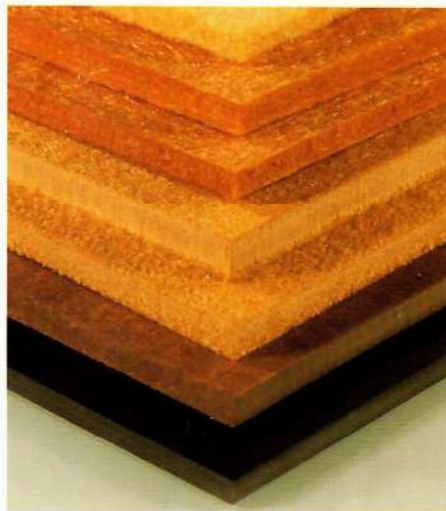

needs. This choice of thickness and density lets you select the proper balance of physical and thermal characteristics without having to compromise.

## Pays for Itself In Months

In most cases, Pyropel pays for itself in energy savings alone in a matter of months. Durable and long-lasting, it continues to yield savings long after other insulations have failed or worn out.

In addition to reducing energy costs, Pyropel also reduces the cost of installing and maintaining insulation. It can also reduce unwanted plant heating, increasing employee comfort and safety.

Most important of all, Pyropel can make your process more efficient and, therefore, faster and more profitable. By allowing more efficient heating and cooling, Pyropel can decrease cycle times and increase line speed, product quality, and profitability.

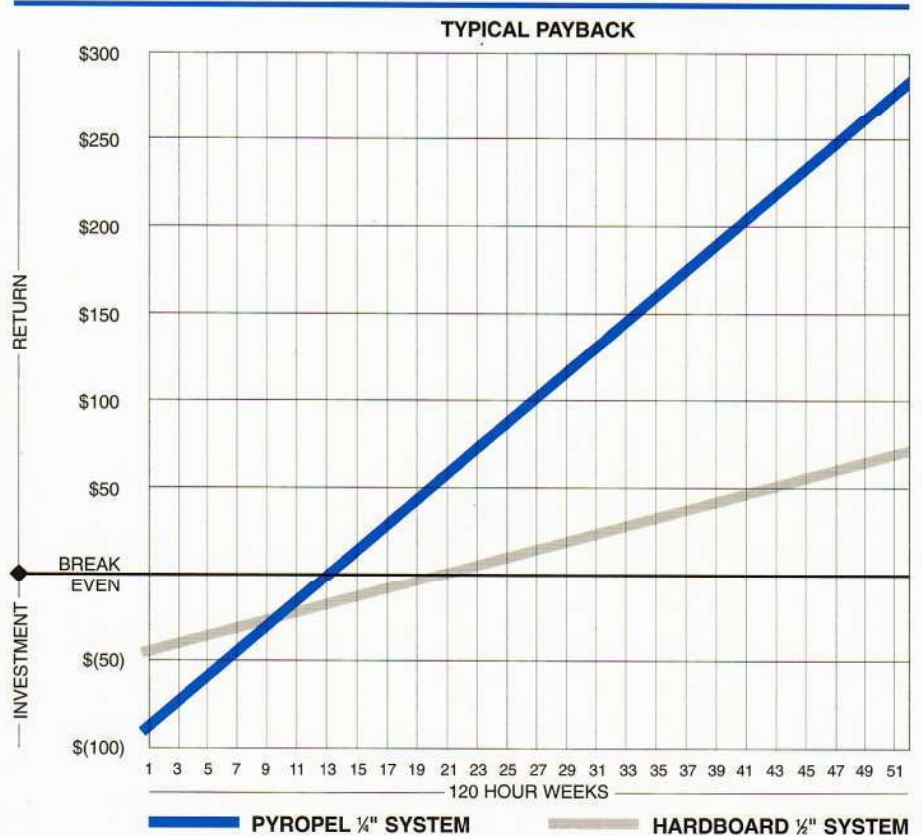



# Superior Performance in a Wide Range of

Used in a wide range of processing applications where more efficient heating and/or cooling are required, Pyropel is particularly well-suited to the demands of plastics and rubber processing.

The following selector guide lists various plastics and rubber processing applications and the recommended Pyropel product(s) for the job.

If you have any questions or need additional assistance, please contact our

**Technical Service Hotline**  
**1-888-PYROPEL**  
**(1-888-797-6735)**



▲ Pyropel insulation ensures optimum temperature and flow conditions needed for thermoset compression molding of electrical wiring devices.

Pyropel tool base insulation not only saves this custom molder hundreds of dollars each year in energy costs, it also increases machine productivity. ▼

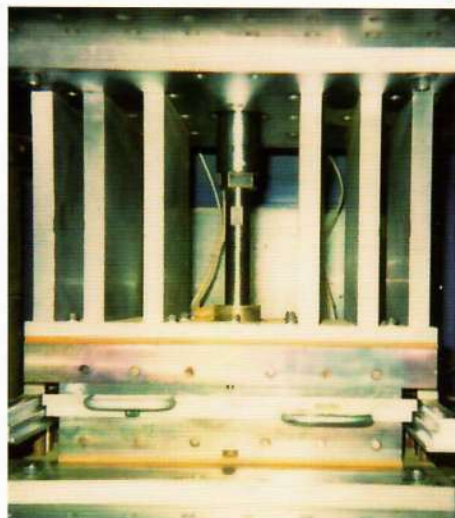

Process	Application
EXTRUSION <i>BARREL COVERS</i>	Pyropel is bonded or mechanically fastened inside of guard.
<i>MOUNTINGS</i>	Pyropel is machined thermal spacers.
COMPRESSION MOLDING <i>PLATENS/TOOL BASE</i>	Pyropel is mounted between heated platen and press bed, as well as between press and heated tool.  Pyropel is normally an option for large, lower pressure molds. Its use requires thermal spacers.
<i>PERIMETER</i>	Used to insulate sides of tooling or heated platens, Pyropel is bonded using high-temperature adhesives or can be mechanically fastened.
INJECTION MOLDING <i>TOOL BASE</i>	Pyropel is mounted to the base using adhesives or counter sunk flat head screws.
<i>HOT RUNNER SYSTEMS</i>	Pyropel can be installed inside the manifold cavity using adhesives. Normally, its thickness should be 1/2 that of the air gap.
<i>THERMOSET/ELASTOMER/RIM</i>	See compression molding and injection molding/tool base.
FILM AND SHEET <i>AIR RINGS</i>	Pyropel is installed between the top die and the air ring. Typically, no fasteners or adhesives are required.
<i>BLOWN FILM DIES</i>	Pyropel is designed into new dies to insulate internal bubble cooling systems. It can also be fabricated into insulation covers to contain and control die heat.
<i>FLAT EXTRUSION DIES</i>	Pyropel is bonded or mechanically fastened to existing dies.  Pyropel is specified as a critical component in new dies. Recommended Pyropel product depends on the demands of each specific application. Pyropel HD should be used in highly critical areas where tight tolerances must be maintained.
SECONDARY PROCESSING OPERATIONS: • HEAT SEALING • DECORATION • BRANDING	

## Legend of Benefits

- |                         |                               |
|-------------------------|-------------------------------|
| 1 Energy savings        | 4 Reduced thickness variation |
| 2 Faster start-up       | 5 Faster line speed           |
| 3 Increased heater life |                               |

# Plastics and Rubber Processing Applications

Recommended Product	Benefits	Comments
MD-12	1, 10, 11	Barrel covers or blankets are normally not used or discarded because of difficulties in servicing the equipment. They also slow down cooling, cause overheating, and can mask heater failures. Insulating the guard provides most of the desired benefits without any drawbacks.
HD	8	
MD-30 MD-50 MD-60	1, 2, 12, 3, 7, 8, 9, 12	Molding pressures under 300 psi Molding pressures between 300 and 600 psi Molding pressures over 600 psi
MD-12 MD-18		Metal or Pyropel HD standoffs are required to withstand loading.
MD-12 MD-18 MD-30	1, 2, 10, 11, 13	In selecting a Pyropel product, users should take into consideration the amount of physical loading the insulation will encounter in normal operation. For high load applications, more rigid Pyropel MD products should be used.
MD-60	1, 7, 8, 13	Maximum pressure limits apply. Functionality is a factor of temperature, pressure, and cycle time.
MD-12 MD-18	1, 2, 3, 7, 13	For maximum effectiveness, the perimeter should be insulated as well as the top and bottom of the cavity.
	1, 2, 6, 7, 8, 10, 11, 12, 13	Care should be taken in the RIM process to avoid overheating caused by the chemical reactions taking place.
MD-12	1, 4, 5, 11	Typically, processors have many die sizes. To maximize material use, Pyropel is normally supplied in sheets, not cut rings. Cutting ring insulators is easy and requires no special knowledge or equipment.
LD-6 MD-12 MD-18	1, 2, 7, 10, 11	In both internal and external applications, Pyropel is self-supporting and requires only limited support systems. Pyropel LD is normally chosen for short-term or small applications. Pyropel MD offers longer term, more permanent solutions.
MD-12 MD-18 Design Driven	1, 2, 3, 4	Typically, extrusion dies have no external loading but benefit from perimeter insulation. This could be applied externally to existing dies or designed as an internal structural plate, isolating the heater section from external structures.

• BAG MAKING

PERIPHERAL EQUIPMENT: • TRANSFER PUMPS • TRANSFER LINES

6 Better tool closure, less flash	8 Reduced thermal stress on equipment	10 Employee safety	12 Reduced cycle times
7 Ease of use	9 No need to grind tool base on large low pressure tools	11 Employee comfort/ Reduced load on plant environmental systems	13 More uniform temperature profile



# Physical Properties

## Products for a Wide Range of Applications

Pyropel is available in three different forms:

### Low Density

A flexible form of Pyropel, Pyropel LD is an industrial nonwoven. Typically used where thermal control is the major engineering concern, Pyropel LD can be easily wrapped around complex shapes or converted into insulation kits. Unlike other blanket type insulators, Pyropel LD is binder-free and has none of the shedding concerns associated with common fiber-based materials.

### Medium Density

Pyropel MD is a lightweight fiberboard with superior insulation properties. Pyropel MD-12, MD-18, and MD-30 are semi-rigid and are normally used in areas that require both thermal isolation and limited mechanical resistance.

Pyropel MD-50 and MD-60 are rigid insulation for mechanically demanding areas. More resilient, MD-50 is ideal when loading is not evenly distributed or when equipment alignment is not perfect. MD-60 is the most structurally rigid grade of Pyropel MD and offers the highest compression resistance and physical tolerances.

### High Density

Pure polyimide plate, Pyropel HD is easily machined to make both mechanical and thermal components for highly engineered equipment. These components include high-temperature spacers, washers, slides, and bearings.

	TEST METHOD	LD		MD-12	
		LD-6		MD-12	
		English	Metric	English	Metric
<b>PHYSICAL</b>					
Form:		Flexible Blanket	Flexible Blanket	Semi-Rigid Fiberboard	Semi-Rigid Fiberboard
Color:		Yellow	Yellow	Gold	Gold
Density:		6 lb/ft <sup>3</sup>	0.10 g/cm <sup>3</sup>	12 lb/ft <sup>3</sup>	.19 g/cm <sup>3</sup>
Standard Thickness: <sup>1</sup>		1/8" - 1"	3.2 - 25.4 mm	1/8" - 3/8"	3.2 - 9.5 mm
Standard Sheet Size: <sup>1</sup>		54" wide	1.37 m	4' x 8'	1.2 x 2.4 m
<b>MECHANICAL</b>					
Tensile Modulus:	D-638	—	—	15,000 psi	107,000 kPa
Yield Strength (2% Offset):	D-638	—	—	1,500 psi	10,340 kPa
% Elongation:					
@ 2% Offset		—	—	6%	6%
@ Break		—	—	31%	31%
Compression Modulus:	D 638	—	—	800 psi	5,500 kPa
Strength @ 2% Strain:	D-695	—	—	10 psi	70 kPa
Flexural Modulus:	D-790	—	—	1,940 psi	13,380 kPa
<b>THERMAL</b>					
Continuous Use Temperature:		575°F	302°C	550° F	288° C
Glass Transition Temp (Tg):		600°F	315°C	600° F	315° C
Thermal Conductivity (k):					
@ 25°C (77°F)		0.22	0.032	0.24	0.036
@ 93°C (200°F)	C-177	0.27	0.039	0.26	0.038
@ 149°C (300°F)		0.31	0.045	—	—
@ 204°C (400°F)		0.38	0.055	0.32	0.046
Flammability Rating:	UL-94	—	—	94V-0	94V-0

<sup>1</sup>Custom sizes and thicknesses available. Consult Technical Services.

## Design Considerations

Pyropel is a superior insulator and is very easy to work with. However, users should consider the following when forming or fabricating it into parts or structures.

- Under normal conditions, Pyropel will not shed fibers, but cutting, milling, drilling, or routing it will generate loose fibers. While these fibers pose no health risks, we recommend that workers wear masks and safety glasses for their own comfort.

- Pyropel provides excellent heat resistance. However, when fabricating Pyropel into components, housings, or other parts, users should consider the heat resistance of any mechanical fasteners or adhesives.

- Manufactured from 100% polyimide, Pyropel offers excellent chemical resistance and is not affected by most strong solvents or acids and many alkali materials. Consult Technical Service for Pyropel's resistance to specific chemicals.



MD								HD	
MD-18		MD-30		MD-50		MD-60		HD Plate	
English	Metric	English	Metric	English	Metric	English	Metric	English	Metric
Semi-Rigid Fiberboard	Semi-Rigid Fiberboard	Semi-Rigid Fiberboard	Semi-Rigid Fiberboard	Rigid Fiberboard	Rigid Fiberboard	Rigid Fiberboard	Rigid Fiberboard	Solid Plastic	Solid Plastic
Gold	Gold	Gold	Gold	Gold	Gold	Light Brown	Light Brown	Black	Black
18 lb/ft <sup>3</sup>	.29 g/cm <sup>3</sup>	30 lb/ft <sup>3</sup>	.48 g/cm <sup>3</sup>	50 lb/ft <sup>3</sup>	.80 g/cm <sup>3</sup>	60 lb/ft <sup>3</sup>	.96 g/cm <sup>3</sup>	85 lb/ft <sup>3</sup>	1.36 g/cm <sup>3</sup>
1/8" - 1/4"	3.2 - 6.4 mm	5/16"	8 mm	5/16"	8 mm	5/32", 1/4"	4, 6.4 mm	1/4", 1/2"	6.4, 12.7 mm
4' x 8'	1.2 x 2.4 m	2' x 3'	0.6 x 0.9 m	2' x 3'	0.6 x 0.9 m	2' x 3'	0.6 x 0.9 m	12" x 12"	305 x 305 mm
27,000 psi	186,200 kPa	31,000 psi	216,500 kPa	110,000 psi	750,000 kPa	164,000 psi	1,150 MPa	570,000 psi	3,930 MPa
1,700 psi	11,720 kPa	670 psi	4,620 kPa	1,960 psi	13,510 kPa	3,070 psi	21,170 kPa	10,000 psi	70 MPa
6% 22%	6% 22%	4% 29%	4% 29%	4% 13%	4% 13%	4% 6%	4% 6%	— 2%	— 2%
2,200 psi	15,170 kPa	15,000 psi	103,420 kPa	46,000 psi	317,160 kPa	58,000 psi	104,110 kPa	540,000 psi	3,720 MPa
15 psi	100 kPa	60 psi	410 kPa	275 psi	1,900 kPa	1,150 psi	7,930 kPa	—	—
6,620 psi	45,640 kPa	20,030 psi	138,100 kPa	49,390 psi	340,530 kPa	132,260 psi	911,910 kPa	550,000 psi	3,790 MPa
550°F	288° C	550°F	288° C	550°F	288° C	550°F	288° C	550°F	288° C
600° F	315° C	600° F	315° C	600° F	315° C	600° F	315° C	600° F	315° C
0.27 0.31 — 0.36	0.041 0.046 — 0.052	0.34 0.36 0.39 0.44	0.049 0.052 0.056 0.063	0.49 0.51 0.56 0.62	0.070 0.074 0.080 0.089	0.80 0.83 0.86 0.90	0.114 0.119 0.123 0.129	1.57 — — 2.09	0.23 — — 0.3
94V-0	94V-0	94V-0	94V-0	94V-0	94V-0	94V-0	94V-0	—	—

## Other Pyropel Applications

If you have questions about or need assistance with any Albany International HPM products, please call our

**Technical Service Hotline:**  
**1-888-PYROPEL**  
**(1-888-797-6735)**

### Aerospace

Originally developed to meet the critical weight and fire safety demands of passenger airplanes, Pyropel is ideal for passenger compartment/cabin applications. Lightweight and easy to fabricate, Pyropel is nonflammable, nontoxic, and produces very little smoke when subjected to flame.

### OEM Applications

Pyropel offers designers benefits that are unmatched by other forms of insulation. Superior insulating ability; light weight;

resistance to heat, fire, chemicals, and mildew; and ease of fabrication make Pyropel the logical choice for products from electronics to refrigerated trucks to the Space Shuttle.

### Acoustic Insulation

In addition to being an excellent thermal insulation, Pyropel offers impressive sound deadening capability. It is particularly well suited to applications where its rigidity and ease of fabrication simplify design or reduce assembly labor.

# Pioneering Advanced Materials for Industry

---

## REGARDING THIS INFORMATION

All statements and technical information contained herein are based on tests we believe to be reliable. There is no guarantee of the accuracy and completeness of the information and the following is made in lieu of all warranties, expressed or implied.

Pyropel, Inc.'s obligation is to replace such quantity of product proved to be defective. Pyropel, Inc. shall not be liable for any injury, loss or damage, direct or consequential, arising out of the use of or the inability to use the product. Users shall determine the suitability of the product for their intended use and assumes all risk and liability whatsoever in connection therewith. Statements relating to possible use are not guaranteed to be free from patent infringement risks or liability.

***PYROPEL, INC.***

20 Howard Avenue  
New Bedford, MA 02745  
Toll-Free: 1-888-Pyropel  
TEL: (508) 273-2628  
[www.pyropel.com](http://www.pyropel.com)